

SS36 SERIES 45° SERRATION

36-T SAE Straight-Sided Disc Type, Finishing Non-Topping

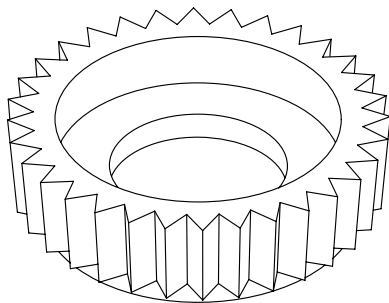

Nom. Dia.	Pitch Dia.	Bore	No. Teeth	Whole Depth	Series
3/16	1.5	1/2	288	.006	SS36-187-H
1/4	1.5	1/2	216	.0082	SS36-250-H
1/4	2.125	1-1/4	318	.0082	SS36-250-2
1/4	3	1-1/4	432	.0082	SS36-250-3
5/16	1.5	1/2	180	.0103	SS36-312-H
5/16	2.25	1-1/4	260	.0103	SS36-312-2
3/8	1.5	1/2	144	.013	SS36-375-H
3/8	2.25	1-1/4	228	.013	SS36-375-2
3/8	3	1-1/4	300	.013	SS36-375-3
1/2	1.5	1/2	108	.016	SS36-500-H
1/2	2.5	1-1/4	180	.016	SS36-500-2
5/8	1.5	1/2	93	.022	SS36-625-H
5/8	2.5	1-1/4	144	.022	SS36-625-2
5/8	3	1-1/4	180	.022	SS36-625-3
3/4	1.5	1/2	72	.0265	SS36-750-H
3/4	3	1-1/4	144	.0265	SS36-750-3
7/8	1.5	1/2	64	.0313	SS36-875-H
7/8	3	1-1/4	128	.0313	SS36-875-3
1	1.5	1/2	54	.0353	SS36-010-H
1	3	1-1/4	108	.0353	SS36-010-3