

Full Fillet, Involute Spline

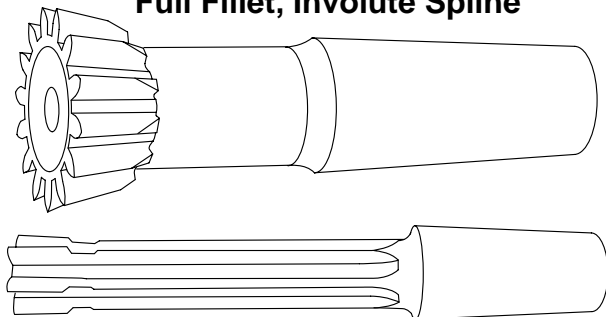

ANSI B92.1-1970/6

Stem design and stroke length vary, please confirm tool specifications with your salesmen.

Maximum Tooth Chart 37-1/2° PA

| Teeth in Gear | Max in Cutter | Teeth in Gear | Max in Cutter |
|---------------|---------------|---------------|---------------|
| 9 | - 4 | 20 | - 15 |
| 10 | - 5 | 21 | - 16 |
| 11 | - 6 | 22 | - 17 |
| 12 | - 7 | 23 | - 18 |
| 13 | - 8 | 24 | - 19 |
| 14 | - 9 | 25 | - 20 |
| 15 | - 10 | 26 | - 21 |
| 16 | - 11 | 27 | - 22 |
| 17 | - 12 | 28 | - 23 |
| 18 | - 13 | 29 | - 24 |
| 19 | - 14 | 30 | - 25 |

KFF37 SERIES DP 37-1/2° PA

| Diam. Pitch | No. Teeth | Approx. Stroke | Whole Depth | Series |
|-------------|-----------|----------------|-------------|-------------|
| 10/20 | 8 | 2-1/4 | .1315 | KFF37-10-8 |
| 12/24 | 10 | 2-1/2 | .1104 | KFF37-12-10 |
| 16/32 | 4 | 1-1/4 | .0790 | KFF37-16-4 |
| 16/32 | 6 | 1-1/2 | .0790 | KFF37-16-6 |
| 16/32 | 10 | 2 | .0790 | KFF37-16-10 |
| 16/32 | 12 | 2-3/4 | .0790 | KFF37-16-12 |
| 16/32 | 14 | 2-1/2 | .0790 | KFF37-16-14 |
| 20/40 | 5 | 1-1/2 | .0645 | KFF37-20-5 |
| 20/40 | 10 | 1-3/4 | .0645 | KFF37-20-10 |
| 20/40 | 14 | 2 | .0645 | KFF37-20-14 |
| 20/40 | 16 | 2-1/4 | .0645 | KFF37-20-16 |
| 24/48 | 5 | 1-1/4 | .0546 | KFF37-24-5 |
| 24/48 | 8 | 1-1/2 | .0546 | KFF37-24-8 |
| 24/48 | 12 | 2-1/2 | .0546 | KFF37-24-12 |
| 24/48 | 18 | 2-1/4 | .0546 | KFF37-24-18 |
| 32/64 | 7 | 1-1/4 | .0445 | KFF37-32-7 |
| 32/64 | 10 | 1-1/4 | .0445 | KFF37-32-10 |
| 32/64 | 20 | 2-1/2 | .0445 | KFF37-32-20 |
| 40/80 | 7 | 1 | .0335 | KFF37-40-7 |
| 40/80 | 10 | 1-1/2 | .0335 | KFF37-40-10 |
| 40/80 | 22 | 1-3/8 | .0335 | KFF37-40-22 |
| 48/96 | 10 | 7/8 | .0285 | KFF37-48-10 |
| 48/96 | 20 | 1-1/2 | .0285 | KFF37-48-20 |