

# SHAPER ADAPTERS

## ADH SERIES 1/2" BORE BUTTON SHAPER

Diam. (M)	Length (L)	Body Diam. (D)	Series
1/2	1/2	1-1/16	ADH-050
1/2	1	1-1/16	ADH-100
1/2	1-1/2	1-1/16	ADH-150
1/2	2	1-1/16	ADH-200
1/2	2-3/4	1-1/16	ADH-275
1/2	3-1/2	1-1/16	ADH-350
1/2	4	1-1/16	ADH-400
1/2	5	1-1/16	ADH-500
1/2	6	1-1/16	ADH-600

1/2 X 13 Threads mounting Diam. ID/taper ID  
Standard Fellows taper (.6235/Ft.) 1.062 Diam.  
taper (large end).

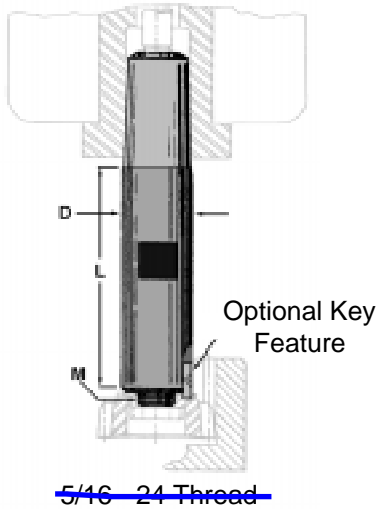

## ADS SERIES 3/4" BORE BUTTON SHAPER

Diam. (M)	Length (L)	Body Diam. (D)	Series
3/4	3/4	1-1/4	ADS-075
3/4	1-1/2	1-1/4	ADS-150
3/4	2	1-1/4	ADS-200
3/4	2-3/4	1-1/4	ADS-275
3/4	3-1/2	1-1/4	ADS-350
3/4	4	1-5/16	ADS-400
3/4	4-1/2	1-3/8	ADS-450
3/4	5-1/2	1-1/2	ADS-550
3/4	6-1/2	1-1/2	ADS-650

1/2 X 13 Threads mounting Diam. ID/taper ID  
ID Standard Fellows taper (.6255/Ft.) 1.062  
Diam. taper (large end).

## AD SERIES 1-1/4" BORE

Diam. (M)	Length (L)	Body Diam. (D)	Series
1-1/4	1/2	2-1/4	AD-050
1-1/4	1/2	3	AD-050B
1-1/4	1	2-1/4	AD-100
1-1/4	1	3	AD-100B
1-1/4	2	2-1/4	AD-200
1-1/4	2	3	AD-200B
1-1/4	3	2-1/4	AD-300
1-1/4	3	3	AD-300B
1-1/4	4	2-1/4	AD-400
1-1/4	4	3	AD-400B
1-1/4	5	2-1/4	AD-500
1-1/4	5	3	AD-500B
1-1/4	6	2-1/4	AD-600
1-1/4	6	3	AD-600B

Standard Large Fellows Taper - (.6235/FT).  
1.062" large end.

1/2 - 13 thread - draw bar (ID). 5/8 - 11  
thread - cutter end (ID). The 2-1/4" is  
standard. The large 3" diameter should be  
used with coarse pitch large 3" diameter  
cutters.

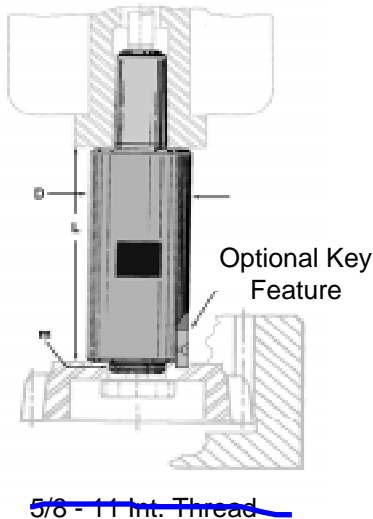

## ADL SERIES 1-3/4" BORE

Diam. (M)	Length (L)	Body Diam. (D)	Series
1-3/4	1/2	2-1/4	ADL-050
1-3/4	1/2	3-1/4	ADL-050B
1-3/4	1	2-1/4	ADL-100
1-3/4	1	3-1/4	ADL-100B
1-3/4	2	2-1/4	ADL-200
1-3/4	2	3-1/4	ADL-200B
1-3/4	3	2-1/4	ADL-300
1-3/4	3	3-1/4	ADL-300B
1-3/4	4	2-1/4	ADL-400
1-3/4	4	3-1/4	ADL-400B
1-3/4	5	2-1/4	ADL-500
1-3/4	5	3-1/4	ADL-500B

Standard Large Fellows Taper - (.6255/FT).  
1.062" large end.

1/2 - 13 thread - draw bar (ID). 5/8 - 11  
thread - cutter end (ID).

## ADE SERIES SPINDLE EXTENSION

Mounting Diam. (M)	Stroke Length (L)	Body Diam. (D)	Series
1-1/4	2-1/4	2-1/4	ADE-200
1-3/4	2-1/4	3	ADE-200L
1-1/4	3	2-1/4	ADE-300
1-3/4	3	3	ADE-300L
1-1/4	4	2-1/4	ADE-400
1-3/4	4	3	ADE-400L
1-1/4	5	2-1/4	ADE-500
1-3/4	5	3	ADE-500L
1-1/4	6	2-1/4	ADE-600
1-3/4	6	3	ADE-600L

*Fits standard 1-1/4 Solid spindle with 1"-10 thread.*

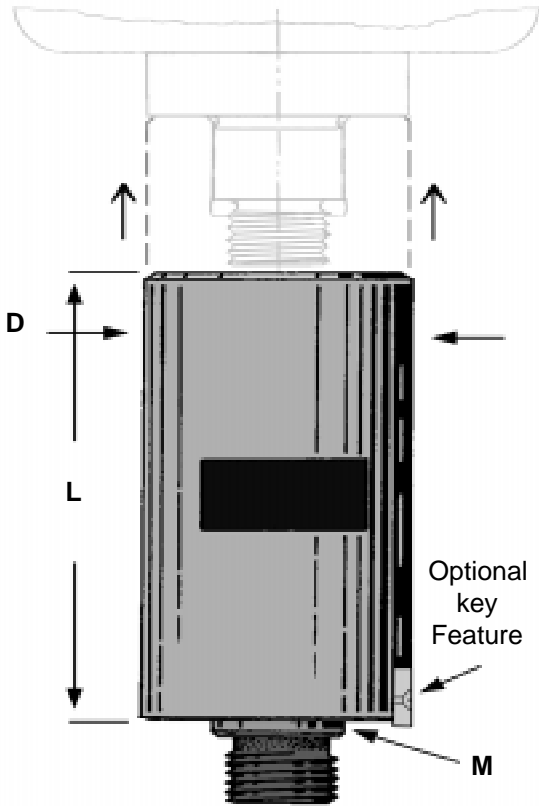

ID 1" - 10 Thread

## ADEP SERIES PRECISION SPINDLE EXTENSION

Mounting Diam. (M)	Stroke Length (L)	Body Diam. (D)	Series
1-1/4	2	2-1/2	ADEP-200
1-1/4	3	2-1/2	ADEP-300
1-1/4	4	2-1/2	ADEP-400
1-1/4	5	2-1/2	ADEP-500
1-1/4	6	2-1/2	ADEP-600

*Fits standard 1-1/4 Solid spindle with 1"-10 thread.*

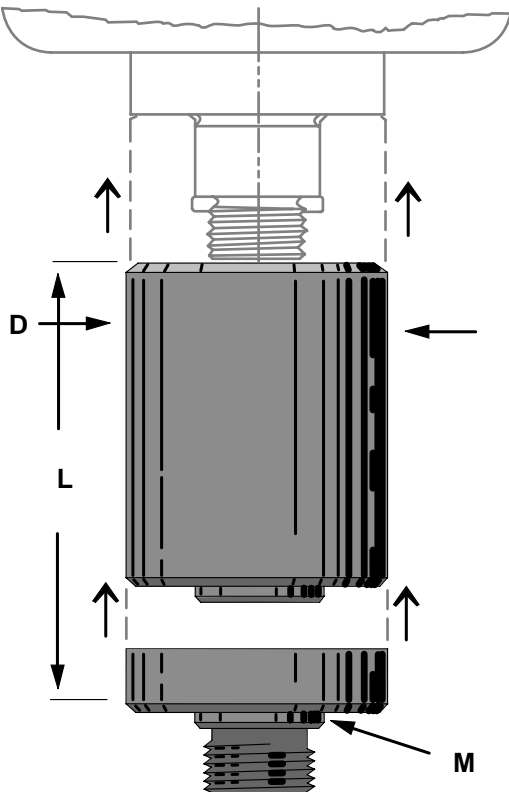

ID 1" - 10 Thread

## ADR & ADT SERIES

Inside Taper (T)	Extension Length (L)	Series
#1 Morse	1/4	ADR-012
#1 Morse	3/4	ADR-075
#1 Morse	1-1/2	ADR-150
#2 Morse	3/4	ADR-007
#2 Morse	1/4	ADR-125
#2 Morse	3/4	ADR-750
#2 Morse	1-1/4	ADR-225
#2 Morse	2	ADR-235
#2 Morse	3	ADR-245
Fellows	2	ADT-200
Fellows	3	ADT-300
Fellows	4	ADT-400

Fellows taper (1.062" large end) on ID & OD thru hole for draw bar 1.062 large end.

Converts standard fellows taper to #1 or #2 Morse taper  
1/2 x 13 threaded ID for draw bar external taper 1.062 large end.

## Large Fellows, Taper Reduction & Spindle Extension

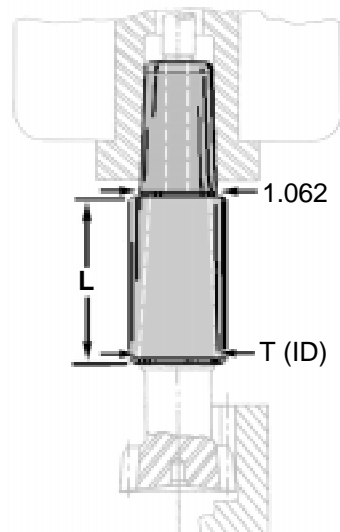

## ADJ SERIES

Internal Taper	Neck Length (NL)	Neck Diam. (ND)	Overall Length (L)	Series
Fellows (1.062 maj. diam.)	1-1/4	1-3/4	3-7/8	ADJ-225
#2 Morse (.700 maj. diam.)	1-1/4	1-3/4	3-1/2	ADJ-750

Fits standard 1-1/4 solid spindle with 1"-10 threads.

## Solid Spindle Adapter to Hold Shank Shapers

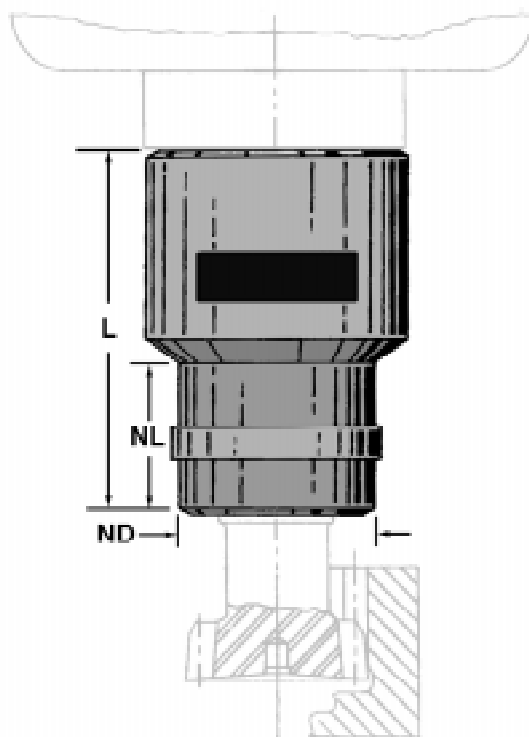

## ADB SERIES

### Solid Spindle Adapter to Hold Button Type Shapers

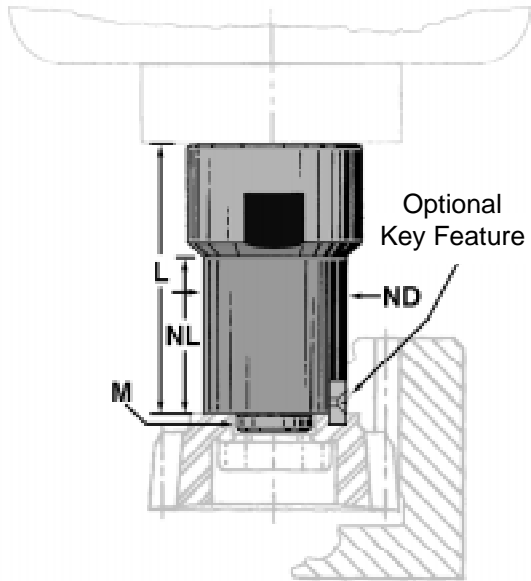

5/16 - 24 Thread

Mounting Diam. (M)	Neck Length (N)	Neck Diam. (ND)	Overall Length (L)	Series
1/2	1	1.350	2-3/4	ADB-501
1/2	2-1/4	1.250	4	ADB-502
1/2	3-1/4	1.250	5	ADB-503
1/2	4	1.250	5-3/4	ADB-504
1/2	5	1.250	6-3/4	ADB-505
3/4	1	1.350	2-3/4	ADB-751
3/4	2	1.350	3-3/4	ADB-752
3/4	3	1.350	4-3/4	ADB-753
3/4	4	1.350	5-3/4	ADB-754
3/4	5	1.350	6-3/4	ADB-755
3/4	6	1.350	7-3/4	ADB-756

Fits standard 1-1/4 solid spindle with 1-10 threads.

## APD SERIES

### Solid Spindle Adapter to Hold Button Type Shapers

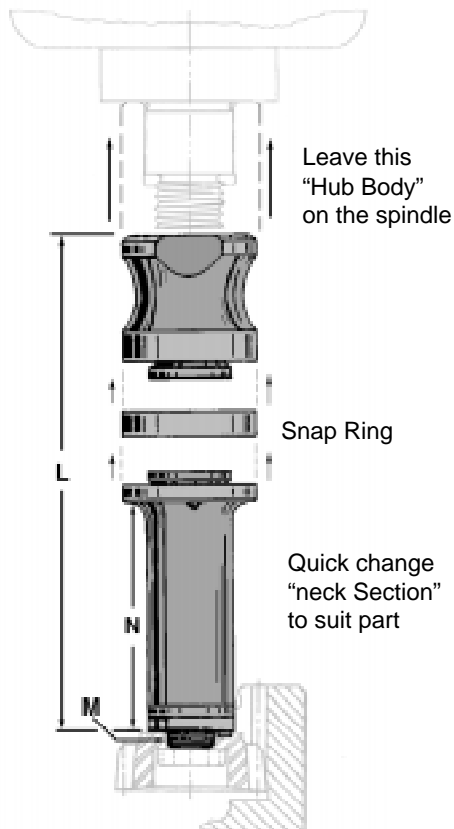

Mounting Diam. (M)	Neck Length (N)	Overall Length (L)	Series
1/2	1	3-1/2	APD-100H
3/4	1	3-1/2	APD-100S
1/2	2	4-1/2	APD-200H
3/4	2	4-1/2	APD-200S
1/2	3	5-1/2	APD-300H
3/4	3	5-1/2	APD-300S
1/2	4	6-1/2	APD-400H
3/4	4	6-1/2	APD-400S
1/2	5	7-1/2	APD-500H
3/4	5	7-1/2	APD-500S
HUB			HUB

Hub bodies are 1-3/4" O.A.L and are interchangeable with all the "neck" sections. Components may be ordered individually.

Set of quick change neck pcs available (1", 3", 5"), please inquire.

## ADH36 SERIES FOR 1/2" BUTTON SHAPERS

Jarno	A	Length (L)	Bolt Center	Body Diam. (D)	Series
16	4	1-1/2	3	1-1/4	ADH36A-150
16	4	2-1/2	3	1-1/4	ADH36A-250
16	4	4-1/2	3	1-1/4	ADH36A-450
18	5	1-1/2	3-1/2	1-1/4	ADH36-150
18	5	2-1/2	3-1/2	1-1/4	ADH36-250
18	5	4-1/2	3-1/2	1-1/4	ADH36-450

## ADS36 SERIES FOR 3/4" BUTTON SHAPERS

Jarno	A	Length (L)	Bolt Center	Body Diam. (D)	Series
16	4	1-1/2	3-1/2	1-1/4	ADS36A-150
16	4	2-1/2	3-1/2	1-1/4	ADS36A-250
16	4	4-1/2	3-1/2	1-3/8	ADS36A-450
18	5	1-1/2	3	1-1/4	ADS36-150
18	5	2-1/2	3	1-1/4	ADS36-250
18	5	4-1/2	3	1-3/8	ADS36-450

## AD36 SERIES FOR 1-1/4" SHAPERS

Jarno	A	Length (L)	Bolt Center	Body Diam. (D)	Series
16	4	1-1/2	3	2-1/4	AD36A-150
16	4	1-1/2	3	3	AD36A-150B
16	4	2-1/2	3	2-1/4	AD36A-250
16	4	2-1/2	3	3	AD36A-250B
16	4	3-1/2	3	2-1/4	AD36A-350
18	5	1-1/2	3-1/2	2-1/4	AD36-150
18	5	1-1/2	3-1/2	3	AD36-150B
18	5	2-1/2	3-1/2	2-1/4	AD36-250
18	5	2-1/2	3-1/2	3	AD36-250B
18	5	3-1/2	3-1/2	2-1/4	AD36-350

## ADL36 SERIES FOR 1-3/4" SHAPERS

Jarno	A	Length (L)	Bolt Center	Body Diam. (D)	Series
16	4	1-1/2	3	3-1/4	ADL36A-150
16	4	2-1/2	3	3-1/4	ADL36A-250
16	4	3-1/2	3	3-1/4	ADL36A-350
18	5	1-1/2	3-1/2	3-1/4	ADL36-150
18	5	2-1/2	3-1/2	3-1/4	ADL36-250
18	5	3-1/2	3-1/2	3-1/4	ADL36-350

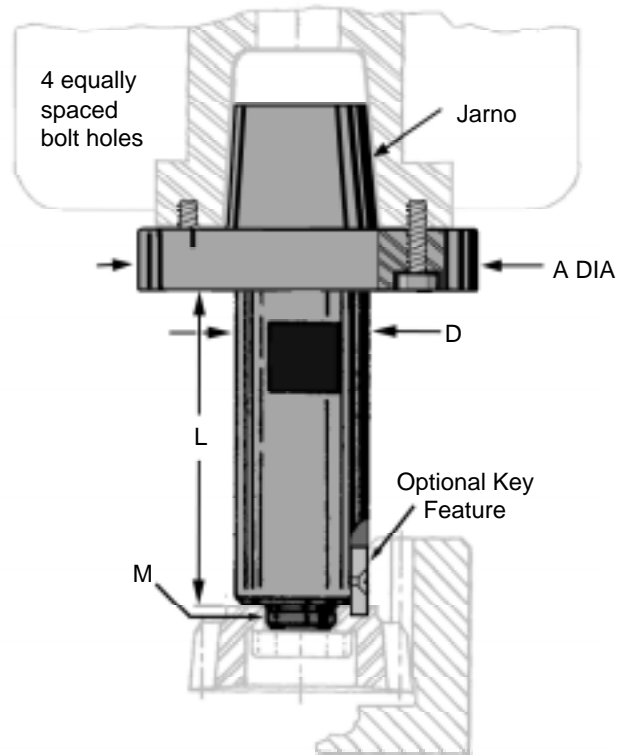

## ADE36 SERIES CONVERSION ADAPTER FOR #36 FELLOWS 1-1/4" MOUNTING DIAMETER

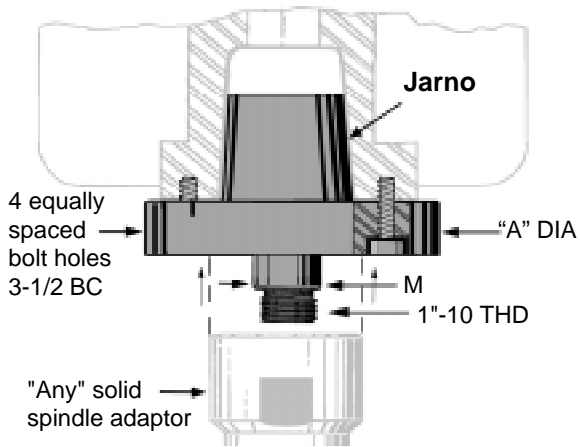

Bolt Hole	Flange "A"	Jarno	
3-1/2	5	18	ADE36-125
3	4	16	ADE36A-125

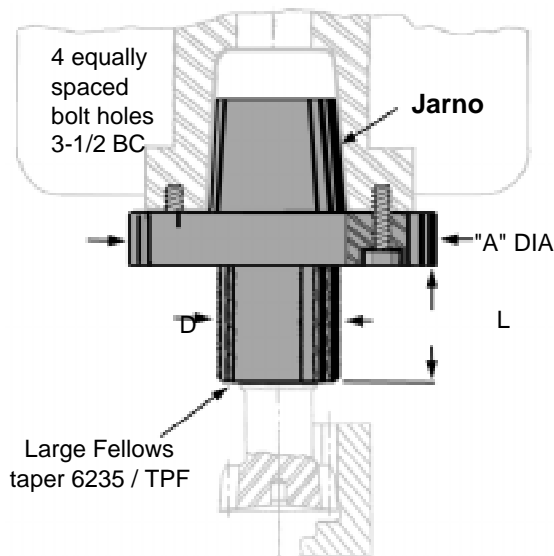

## ADR36 SERIES ADAPTER FOR #36 FELLOWS TO HOLD SHANK SHAPERS

"A" Flange	Bolt Hole CD	Length (L)	Body Diam. (D)	Jarno	Series
5	3-1/2	3/4	1-1/2	18	ADR36-075
4	3			16	ADR36A-075
5	3-1/2	2-1/2	1-9/16	18	ADR36-250
4	3			16	ADR36A-250
5	3-1/2	4-1/2	1-5/8	18	ADR36-450
4	3			16	ADR36A-450

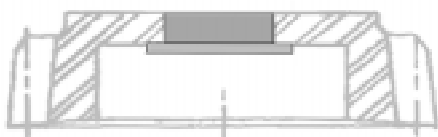
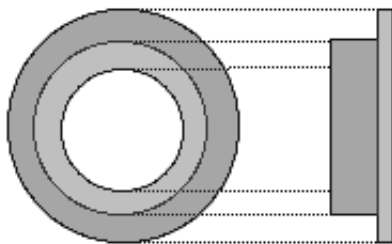

## ASR SERIES SHAPER BORE REDUCTION RING

Exter. Diam.	Inter. Diam.	Series
1-3/4	1-1/4	ASR-175
3-1/2	3	ASR-350*

*For use with helical or spur disc type shaper cutters.*

*\*Designed for use with herringbone shapers.*